

SCHEMPP-HIRTH FLUGZEUGBAU GmbH, KIRCHHEIM-TECK
WEST GERMANY

=====

F L I G H T M A N U A L
for the Sailplane

J A N U S C

Translation of the German Manual
Issue: June 1980

This Manual should always be carried
in the Sailplane.

It belongs to the Sailplane

Model: J A N U S C

Registration No.: F-CVSL

Serial No.: 123

Schempp-Hirth
Flugzeugbau GmbH
Krebenstraße 25 - Postfach 14 43
D-7312 Kirchheim unter Teck
LBA-Nr. 1 B 5

Manufacturer:

Owner: PPBS, Aérodrôme de la forêt,
71600, PARAY LE MONIAL

The translation is approved as far as it
covers the original German text.

Approval of translation has been done by best knowledge
and judgement. - In any case the original text
in German language is authoritative.

01. Juli 1982



Schmaljohann

JANUS C

FLIGHT MANUAL

Table of contents	Page
Amendment list	2
Introduction	3
Three-sides view	4
<u>2. Operating limits</u>	
2.1 Airspeeds	5
2.2 Airworthiness category	7
2.3 Load factors	8
2.4 Weights	8
2.5 Loading plan	9
2.6 C.G. positions	11
Weight and balance log sheet	14
2.7 Weak links in the tow rope	15
2.8 Tow release hook	15
2.9 Minimum equipment	16
2.10 Restricted aerobatics	18
2.11 Assembly data	18
<u>3. Emergency procedures</u>	
3.1 Spin recovery	20
3.2 Safety considerations	20
3.3 Emergency canopy jettison	21

June 1980









JANUS C

FLIGHT MANUAL

<u>Table of contents</u>	<u>Page</u>
4. <u>Normal operations</u>	
4.1 Dayly inspections	22
4.2 Cockpit description	25
4.3 Pre-take-off checks	33
4.4 Take-off	33
4.5 Free flight	35
4.6 Low speed flight and stall	37
4.7 High speed flight	39
4.8 Flight with water ballast	40
4.9 Cloud flying	42
4.10 Flying at temperatures below freezing point	42
4.11 Restricted aerobatics	43
4.12 Approach and landing	44

June 1980

AMENDMENT LIST
(log of revisions)

No.	Reference / short title	Page	Date
1.	Technical Note No. 295 - 9: Optional installation of a nose tow hook	15,23 33,34	July 1980 
2.	Technical Note No. 295 - 6: Installation of the tail chute omitted (optional)	28, 31,32	Sept. 1980 
3.	Modif. Bulletin No. 295 - 21: Optional retractable main wheel with hydraulic disc brake (when converted according to method "b", page 27 and 44 are omitted)	3,4,5 9,19,25 27,29 30,32 33,44	Jan. 1981 
4.	Technical Note No. 295 - 13: Optional hydraulic disc brake for fixed main wheel (when con- verted according to method "b", page 27 and 44 are omitted)	27, 32,44	Febr. 1983 
5.	Modif. Bulletin No. 295 - 23: Supplements to section 2.5 (loading plan) and 2.6 (C.G. positions). (Optional up to S/N 180, standard on S/N 181 and up)	9,12 13A 13B, 14,31	Dec. 1983 
6.	Technical Note No. 295 - 17: Optional installation of a tail wheel (instead of standard skid).	12,24	Dec. 1985 
7.	Technical Note No. 295 - 18: Optional mounting provision for trim ballast weights	9,31	May 1987 
8.	Modif. Bulletin No. 295 - 24: High altitude flying (warning)	42 A	1987 

AMENDMENT LIST
(log of revisions)

No.	Reference / short title	Page	Date
9.	<u>Modification Bulletin No. 295-25</u> Optional adjustable rudder pedals for rear seat	25, 26A	Nov.. 1987
10.	<u>Modification Bulletin No. 295-27</u> Supplements relating to section 4.4 "aerotow"	33	Aug. 1989
11.	<u>Technical Note No. 295-20</u> Tow releases „EUROPA G 88" and „E 85", weak link	15, 30	April 1990
12.	<u>Technical Note No. 295-23</u> Safety clip for „L'Hotellier" ball and swivel joints	supplement. page	April 1993
13.	<u>Technical Note No. 295-24</u> „Wedekind" safety sleeve for „L'Hotellier" ball and swivel joints	supplement. page	Feb. 1994
14.	<u>Technical Note No. 295-25</u> Enlarged fin/rudder unit -optional use-	4, 19, 28, 31, 32, 35, 43, 44	June 1994
15.	<u>Technical Note No. 295-28</u> Empty mass c/g positions for various <i>minimum front seat loads</i> -optional up to S/N 178	8, 12, 13A, 13B, 14, 31	July 1999
16.	<u>Technical Note No. 295-29</u> Minimum front seat load with two occupants - optional for all serial numbers-	9	April 2000

1. Introduction

The JANUS C is a two-seat high performance sailplane in carbon and glass fibre construction, with flaps and a stabilized T-tailplane.

Wing: The four-piece wing has a double trapezoid planform and is fitted with Schempp-Hirth air brakes on the upper surface. The flaps and ailerons have internal drives. The water tanks are integrated in the wing structure and have a capacity of 120 litre each. The wing shell is of carbon fibre-foam-sandwich with spar flanges of carbon fibre rovings and spar webs of GRP-foam-sandwich.

Fuselage: The comfortable cockpit provides a tandem arrangement for the pilots. The one-piece canopy hinges sideways. The fuselage shell is a pure glass fibre lay-up without sandwich and therefore is highly energy absorbing. The forward fuselage shell is reinforced on both sides with a second skin in which the canopy frame is integrated. The rear part of the fuselage is reinforced by GRP-sandwich webs. The JANUS-C has a retractable main wheel and a fixed nose wheel. The main wheel features a hydraulic disc brake.

Horizontal Tailplane: The stabilizer is built in carbon/glass fibre-foam-sandwich and the elevators in pure carbon/glass fibre lay-up. The spring loaded trim is adjusted gradually by a click-stop device.

Vertical Tailplane: Fin and rudder are built in glass fibre-foam-sandwich.

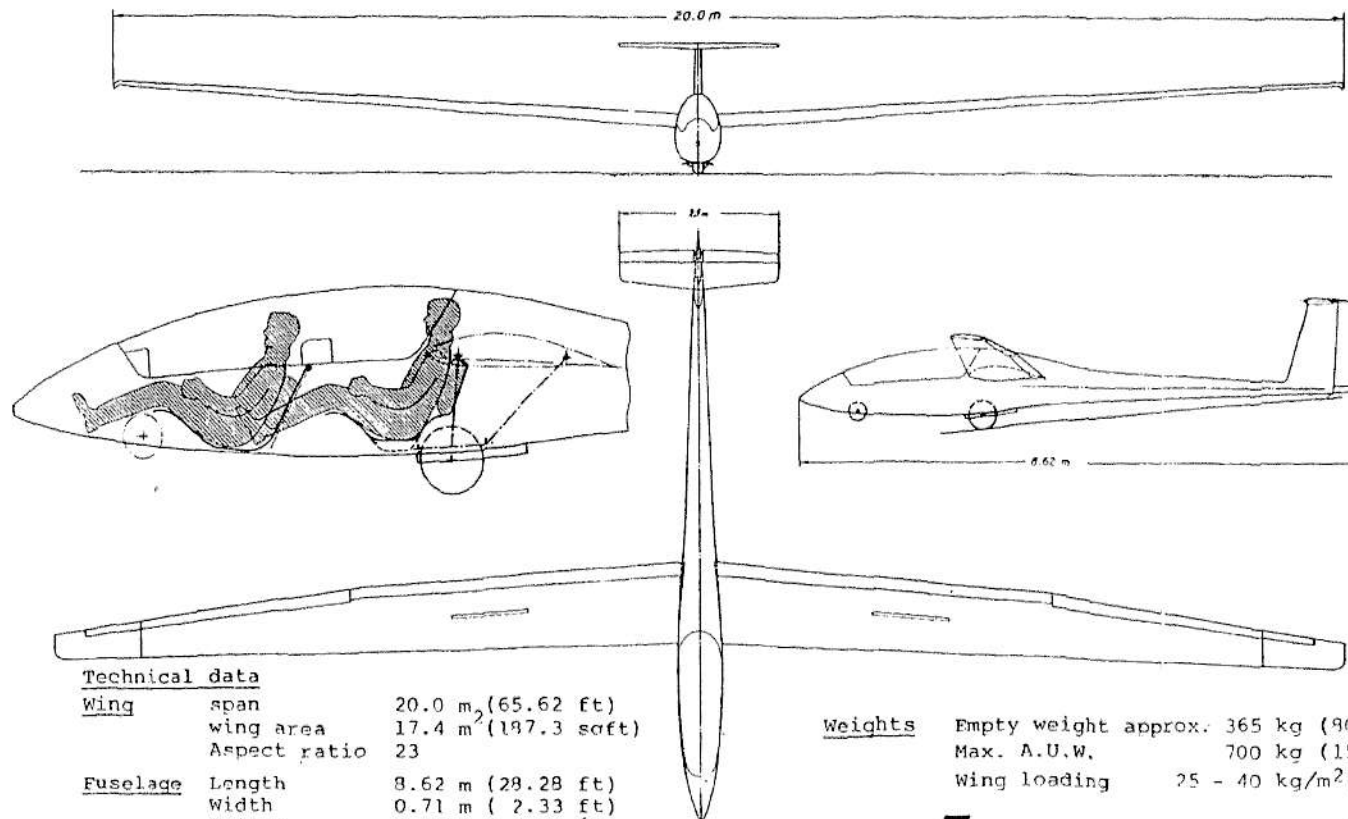

Technical data

<u>Wing</u>	span	20.0 m (65.62 ft)
	wing area	17.4 m ² (187.3 sqft)
	Aspect ratio	23
<u>Fuselage</u>	Length	8.62 m (28.28 ft)
	Width	0.71 m (2.33 ft)
	Height	1.00 m (3.28 ft)

<u>Weights</u>	Empty weight approx.	365 kg (905 lbs)
	Max. A.U.W.	700 kg (1543 lbs)
	Wing loading	25 - 40 kg/m ² (5.2-8.2 lb/sqft)

Janur C

2. Operating Limits

2.1 Airspeeds (IAS)		<u>km/h</u>	<u>knots</u>
Maximum speed Flap settings +8,0,-4,-7	V_{NE}	250	135
Maximum speed Flap setting L	V_{FE}	140	76
Maximum speed Rough air	V_{RA}	180	97
Maneuvering speed	V_A	180	97
Maximum speed Aerotow	V_T	180	97
Maximum speed Auto- and winch tow	V_W	150	81
Maximum speed for undercarriage extension	V_{LO}	180	97

All airspeeds in this manual are indicated airspeeds (IAS) unless otherwise defined.

When flying in higher altitude it is to be considered that the true airspeed (TAS) is higher than the indicated speed (IAS). This is of no consequence with regard to the *stressing of the sailplane*, but for flutter prevention the following indicated speeds should not be exceeded:

Height	V (IAS)		Height	V (IAS)	
m	km/h	knots	m	km/h	knots
0	250	135	6000	205	111
1000	250	135	7000	193	104
2000	250	135	8000	182	98
3000	240	129	9000	172	93
4000	227	122	10000	161	87
5000	215	116	12000	140	76

JANUS C

FLIGHT MANUAL

Airspeed Indicator, pressure error

The calibration curve below shows the error in the ASI reading due to the location of the pressure intake.

Pot pitot: Nose of fuselage

Static vents

ASI : Fuselage tailcone 1 m forward of the fin

Variometer and Altimeter: Canopy frame 6 cm forward of the front instrument panel

All airspeeds quoted in this Manual are indicated airspeeds.

This calibration curve is also valid for winch launching and aerotow using the C.G. tow hook and for aerotow using the nose hook if installed.

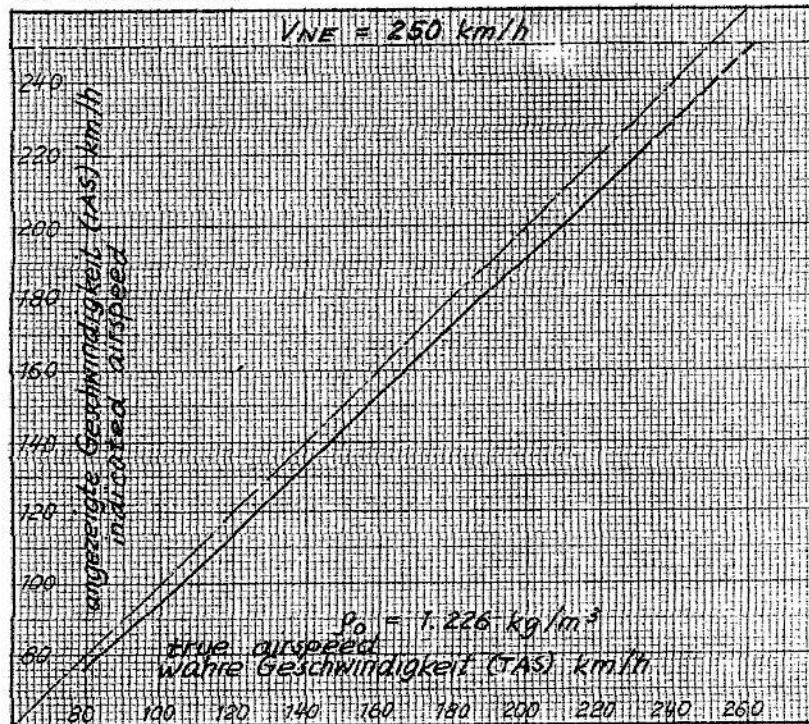

June 1980

2.2 Airworthiness Category

U (Utility) to LFSM.

This sailplane can be operated for VFR by daylight when equipped according to Section 2.9.

According to the LFSM requirements, full control movements may be applied up to the manoeuvring speed $V_A = 180$ km/h or 97 knots.

At higher speeds, it would be possible to exceed the stress limits of the sailplane when using full control movements. For this reason, full control movements must not be used at speeds in excess of 180 km/h or 97 knots.

At the maximum permissible speed of $V_{NE} = 250$ km/h or 135 knots only a maximum of 1/3 of full control movement is permissible.

For the elevator, the deflection at V_{NE} is even considerably smaller, and is limited by the permissible manoeuvring load factors.

This sailplane, in normal weather conditions, can be flown through the full speed range up to $V_{NE} = 250$ km/h or 135 knots.

In strong turbulence, i.e. in wave rotor, cumulo nimbus, visible whirlwinds or when crossing mountain ridges, $V_{RA} = 180$ km/h or 97 knots must not be exceeded.

June 1980

2.3 Load factors

The following manoeuvring load factors must not be exceeded:

at $V_A = 180$ km/h, 97 knots

with air brakes closed $n = + 5.3$

$n = - 2.65$

at $V_{NE} = 250$ km/h, 135 knots

with air brakes closed $n = + 4.0$

$n = - 1.5$

with air brakes extended $n = + 3.5$ max.

2.4 Weights

Empty weight, approx. 365 kg, 805 lbs

Maximum take-off weight 700 kg, 1543 lbs

Maximum weight of
non-lifting parts 400 kg, 882 lbs

Permissible water ballast

see Section 2.5

June 1980

2.5 Loading table

Seat load (Crew incl. parachutes)

Seat load		two persons		one person	
		min.	max.	min.	max.
front seat	kg	70 *	110 *	70 *	110*
	lbs	154	242	154	242
back seat	kg	no limit	110 *	---	---
	lbs		242		

* Note: As the actual minimum or maximum seat load of this sailplane to which this manual refers may differ from the above typical weights, the seat load placard in the cockpit must always show the actual weights from the log chart on page 14.

At less cockpit load, compensating ballast on the front seat is required. The ballast weight (lead or sand cushion) is to be securely fastened onto the front seat belt attachment fittings.

Neither the maximum A.U. weight nor the max. weight of the non-lifting parts must be exceeded.

C.G. position of the pilots

(with parachute or back cushion)

Front seat: 1300 mm (51.18 in.) ahead of datum
 Back seat: 190 mm (7.48 in.) ahead of datum

Baggage compartment

The baggage compartment behind the wing spar stubs is suitable for installation of fixed equipment like oxygen cylinders or variometer flasks and/or for storage of light baggage like jackets etc.

For the determination of the rearward empty weight C.G. a removable baggage load of 5 kg (11 lb) maximum is considered.

Lever arm of the baggage:

1100 mm (43.3 in.) aft of datum (BE)

Note: With both seats occupied, the placarded minimum front seat load may be reduced by the nose-heavy moment of loads on the rear seat as follows:

Rear seat load (kg/lb) x 0.23 = load to be deducted from placarded minimum front seat load (kg/lb)

Example:

Load on:	Both seats occupied	Placarded minimum may be reduced by
Front seat	85 (placarded minimum)	70 x 0.23 = 16 kg
Rear seat	70	

Thus the minimum front seat load of this example is 69 kg.

The seat load placard in the cockpit, however, remains unchanged !

Loading instruction

for the glider with water ballast.

The permitted maximum weight with water ballast is 700 kg, 1543 lb.

Weight of water ballast at different empty weights and cockpit loads, single or two-seat:

Empty weight (kg)	Cockpit load (kg)									
	70	80	100	120	140	160	180	200	220	
	Water ballast (kg) - both tanks									
350	240	240	240	230	210	190	170	150	130	
360	240	240	240	220	200	180	160	140	120	
370	240	240	230	210	190	170	150	130	110	
380	240	240	220	200	180	160	140	120	100	
390	240	230	210	190	170	150	130	110	90	
400	230	220	200	180	160	140	120	100	80	
410	220	210	190	170	150	130	110	90	70	

Empty weight (lb.)	Cockpit load (lb.)									
	154	180	220	260	300	350	400	450	485	
	Water ballast (lb.) - both tanks									
780	530	530	530	503	463	413	363	313	278	
800	530	530	523	483	443	393	343	293	258	
820	530	530	503	463	423	373	323	273	238	
840	530	523	483	443	403	353	303	253	218	
860	529	503	463	423	383	333	283	233	198	
880	509	483	443	403	363	313	263	213	178	
900	489	463	423	383	343	293	243	193	158	

June 1980

When determining the max. permissible water ballast the not fixed baggage load (max. 5 kg) is to be considered.

2.6 C.G. Positions

a) C.G. range in flight (at all weights)

Leveling means: Slope of rear top surface
of fuselage 100 to 4.5,
tail down

Datum (BE): Wing leading edge at root rib

Max. forward C.G. : 40 mm, 1.58 in.

Max. rearward C.G. : 270 mm, 10.63 in.

behind of datum (BE)

It is very important that the maximum permitted rearward C.G. position is not exceeded, which is warranted when the minimum front seat cockpit load is observed. Less cockpit load must be balanced by ballast, see also loading plan, Section 2.5.

b) Empty weight C.G. position

This sailplane must be weighed at least once every four years, after repairs of major nature, after additional equipment, and after a new painting etc.

It is important to ensure that the empty weight C.G. is within the permitted limits. If necessary, compensating ballast weight must be installed.

If the empty weight C.G. limits and the loading plan are observed, the C.G. position in flight will be within the permitted limits.

If a modification of the loading plan should be necessary, consult with the manufacturer.

See Maintenance Manual pages 17 and 18 for the determination of the C.G. position.

June 1980

The determination of the C.G. ranges as shown in the diagrams on page 13 A and 13 B is done with the following seat loads:

Forward C.G. positions : With a maximum front seat load of 110 kg (242.5 lb) and a max. back seat load of 110 kg (242.5 lb)

Rearward C.G. positions : With various minimum front seat loads and 5 kg (11 lb) load in the baggage compartment

For easier determination of the "empty" weight C.G. position, the table below shows, at various empty weights, the maximum permissible loads on the tail skid (or wheel - if installed) with various seat loads (with reference to the rear-most C.G. position).

Just determine the actual load on the tail skid (or wheel) with the sailplane being in horizontal position (main wheel on the ground, tail jacked up approx. 42 cm/16.5 in. above floor level - this is the position as described on page 11, section 2.6 a).

If the determined load on the tail skid (or wheel) is below the value shown in the table, the C.G. position is within the permitted range.

For sailplanes fitted with a tail wheel, the values in the table below must be increased by a factor of 1.007.

Empty weight kg lb		Load on tail skid (or wheel) with a front seat load of:							
		70 kg	154 lb	75 kg	165 lb	80 kg	176 lb	85 kg	187 lb
350	772	27.0	59.5	28.5	62.8	30.0	66.1	31.5	69.4
360	794	27.2	60.0	28.7	63.2	30.2	66.6	31.7	69.9
370	816	27.4	60.4	28.9	63.7	30.4	67.0	31.9	70.3
380	838	27.6	60.8	29.1	64.1	30.6	67.4	32.1	70.7
390	860	27.8	61.3	29.3	64.6	30.8	67.9	32.3	71.2
400	882	28.0	61.7	29.5	65.0	31.0	68.3	32.5	71.6
410	904	28.2	62.1	29.7	65.5	31.2	68.8	32.7	72.1
420	926	28.4	62.6	29.9	65.9	31.4	69.2	32.9	72.5

JANUS C

FLIGHT MANUAL

EMPTY WEIGHT C.G. RANGE

Permitted forward C.G. position at maximum seat load of 110 kg (242.5 lb)

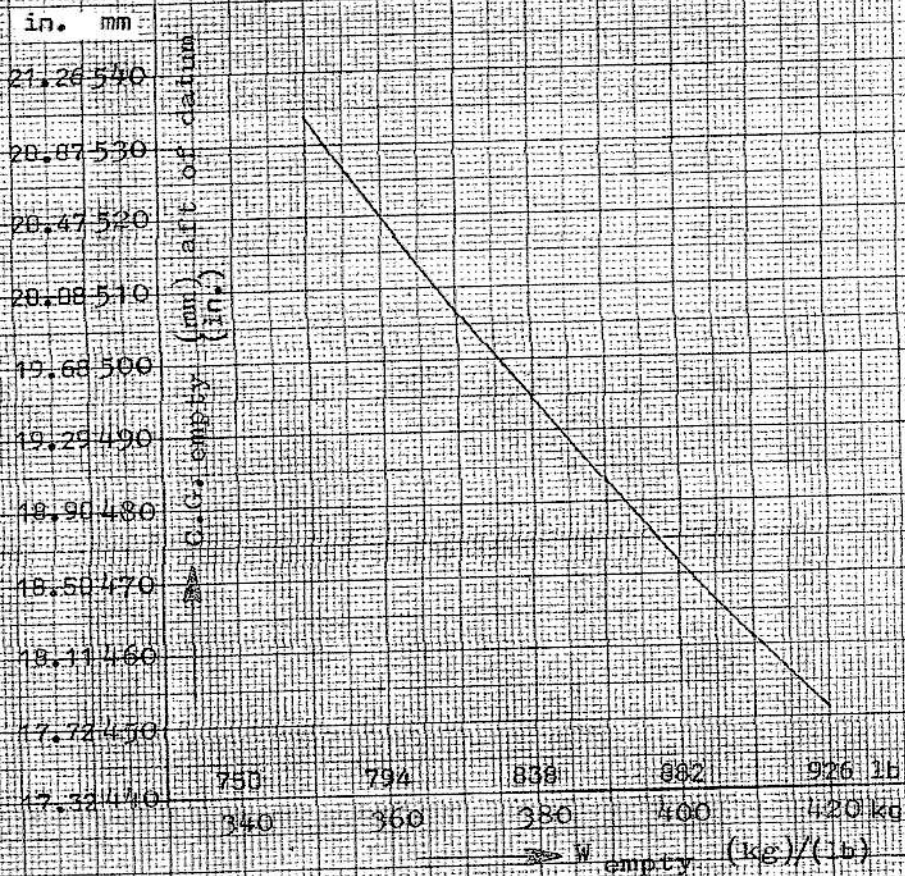

Maximum take-off weight $W_{max} = 700 \text{ kg}$
 1543 lb

JANUS C

FLIGHT MANUAL

EMPTY WEIGHT C.G. RANGE

Permitted rearward C.G. position
at minimum seat loads of:

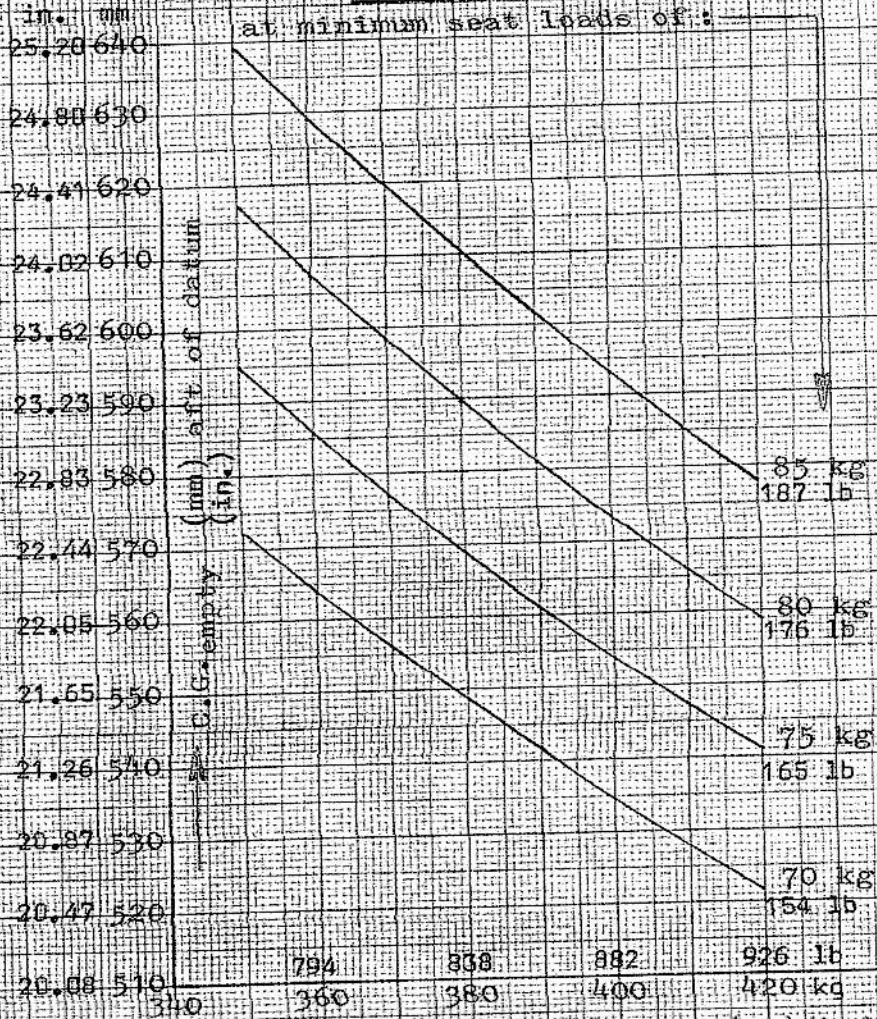

W_{empty} (kg)/(lb)

Maximum take-off weight W_{max} = 700 kg
1543 lb

Weight and Balance Log Sheet

Date of weighing	05.03.15				
Inspector Signature Stamp	K. Hoffmann				
Empty weight	417,6 kg				
Equipment List dated	03.03.15				
Empty weight C.G. position aft of datum	569 mm				
Pilot & 'chute front seat	max.	110 kg			
	min.	85 kg			
Pilot & 'chute back seat	max.	110 kg			
Maximum Payload	199,1 kg				
Water ballast at maximum Payload	82 kg				

Mod. Bulletin No. 295-23

December 1983

JANUS C

- 14 -

FLIGHT MANUAL

Janus C

FLIGHT MANUAL

2.7 Weak links in winch cable/tow rope

For winch launching and aerotow:

Max. 825 daN (1819 lb)

2.8 Tow releases

C/G tow release

For winch launching (and aerotow - unless a nose tow release is fitted) the TOST safety release mechanism model

"EUROPA G 72" or
"EUROPA G 73" or
"EUROPA G 88"

is used, which is installed on the bottom of the fuselage just in front of the main landing wheel.

Nose tow release (if installed)

For aerotow the TOST nose tow release mechanism model

"E 72" or
"E 75" or
"E 85"

is used, which is installed in the nose of the fuselage.

2.9 Minimum Equipment

Instruments and other basic equipment must be of an approved type and should be selected from the list in the Maintenance Manual.

a) Normal operation

- 2 Airspeed indicators up to 300 km/h (162 knots) with colour marking in accord with page 17
- 2 Altimeters
- 2 Four-piece safety harnesses (symmetrical)
- 2 Automatic or manual parachutes, or seat back cushions (approx. 100 mm thick when compressed).

b) Cloud flying

In addition to the equipment listed in a) :

- Turn & Bank indicator with slip ball
- Magnetic Compass
- Variometer
- Glider Radio

Note

From experience to date it appears that the A.S.I. installation remains fully operational when cloud flying.

Recommended items

- Artificial Horizon, Clock,
- Accelerometer (3 hands, resettable)

June 1980

Note

For structural strength reasons the weight of the instrument panels with instruments installed must not exceed 15 kg each.

Operating instructions

Flight and Maintenance Manual

Data and reference placards (see pages 30-32)

Colour marking of the A.S.I.

Maximum speed	$V_{NE} = 250 \text{ km/h}$ 135 knots
Manoeuvring speed	$V_A = 180 \text{ km/h}$ 97 knots
1.1 x stalling speed	$1.1 \times V_{S1} = 81 \text{ km/h}$ 44 knots
White Arc (flap setting L)	81 - 140 km/h 44 - 76 knots
Green Arc (normal range)	89 - 180 km/h 48 - 97 knots
Yellow Arc (warning range)	180 - 250 km/h 97 - 135 knots
Red radial dash (never exceed)	at 250 km/h 135 knots
Yellow triangle (approach)	at 105 km/h 57 knots

The stalling speed V_{S1} of which the A.S.I. markings are based, assume the following configuration:

- a) flap setting : L
- b) air brakes : retracted
- c) maximum weight : 700 kg (1543 lbs)

With air brakes extended the stalling speed increases about 10% !

June 1980

2.10 Restricted Aerobatics

The following aerobatic manoeuvres are approved :

- a) Inside Loops
- b) Spins
- c) Stall Turns
- d) Lazy Eight

It is recommended that in addition to the instrumentation listed in 2.9 a) an accelerometer (3 hands, resettable) be installed.

Aerobatics are only permitted without water ballast.

Loose items should be removed.

2.11 Assembly data

Assembly data and required control surface movements may be found on the next page.

Care should be taken to ensure that these measurements remain accurate *within the permitted tolerances* after repairs.

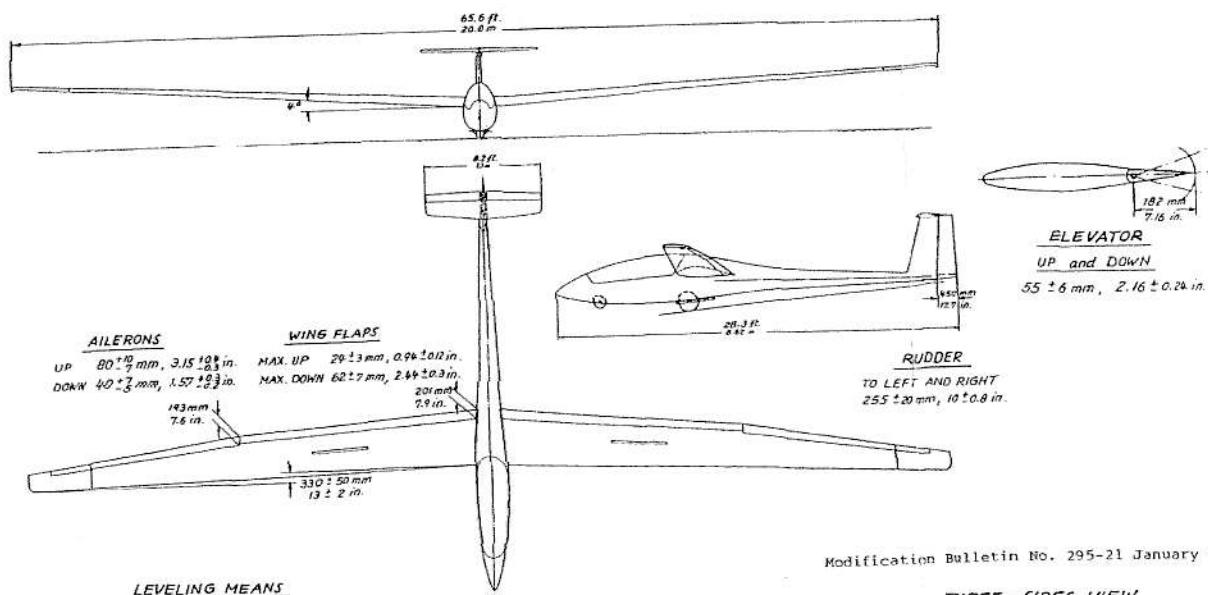

AILERONS
 UP 80 ± 10 mm, 3.15 ± 0.3 in.
 DOWN 40 ± 7 mm, 1.57 ± 0.3 in.

WING FLAPS
 MAX. UP 29 mm, 0.94 ± 0.02 in.
 MAX. DOWN 62 mm, 2.44 ± 0.3 in.

ELEVATOR
 UP and DOWN
 55 ± 6 mm, 2.16 ± 0.24 in.

RUDDER
 TO LEFT AND RIGHT
 255 ± 20 mm, 10 ± 0.8 in.

LEVELING MEANS
 SLOPE OF REAR TOP SURFACE OF FUSELAGE
 100 TO 4.5 TAIL DOWN
 i.e. MAIN LANDING WHEEL ON THE GROUND AND
 TAIL JACKED UP 4.2 cm (16.5 in.) FROM THE GROUND.

Modification Bulletin No. 295-21 January 83

THREE-SIDES VIEW
 CONTROL SURFACE MOVEMENTS

JANUS C

3. Emergency procedures

3.1 Spin recovery

If the sailplane with the C.G. in medium or rear positions unintentionally enters a spin, the control stick should be eased forward immediately and the rotation be recovered by applying opposite rudder control. It is very important to ease the control stick forward to prevent the sailplane from entering a spin in the reverse direction due to the opposite rudder control.

3.2 Safety considerations

Take-off by aerotow or winch launching from un-cut grass fields should be avoided. If a wing tip is caught in the grass, release immediately to avoid a break-out with resulting ground loop (risk of damage).

After emergency release in low altitude, a speed of 95 to 105 km/h (51 to 57 knots) in straight flight, depending on the wing loading and flap setting, should be observed.

In circling flight the speed is to be increased according to the angle of bank. This will avoid that the sailplane is inadvertently and unnoticeably flown in a stalled condition.

If a light vibration is observed and the controls feel spongy, the sailplane in straight flight then is in a stalled condition, in spite of A.S.I. readings of 62 to 89 km/h (33 to 48 knots), dependent on wing loading and flap setting. The control stick then should be eased forward immediately.

June 1980

3.3 Emergency Canopy Jettison

The roomy and well faired cockpits warrant a quick and safe bailing out in emergency.

The procedure to jettison the canopy is :

1. Pull the RED knob on the left canopy frame BACKWARD.
2. Pull the RED knob under the right canopy frame BACKWARD.
3. Throw the canopy clear.

The cable which holds the opened canopy in place is released when pulling the red knob under the right canopy frame backward for jettison.

The fuselage canopy frame is built of a strong laminate without sharp edges, so that the pilots can use it for support.

Connecting the L'Hotellier control rod couplings -
securing them with a "Wedekind" safety sleeve

Pull back spring-loaded safety sleeve and push swivel joint fully home over the ball joint with the wedge-shaped locking slide held open.

When properly connected and locked, the wedge-shaped slide must have moved slightly back so that the "Wedekind" safety sleeve, once released, will be pushed over the wide end of the locking slide, thus preventing an unintentional disconnection.

Test

Check coupling(s) for proper connection by pulling crosswise with a hand force of about 5 daN (11 lb) in the direction of "releasing".

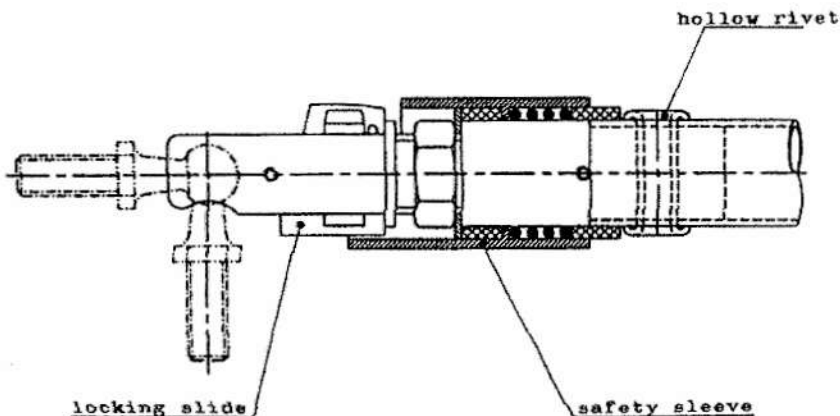

4. Normal Operations

4.1 Daily Inspections

It is very important to inspect the sailplane after assembly respectively before the first start of each day's flying, for often accidents occur when neglecting these inspections or carrying them out carelessly.

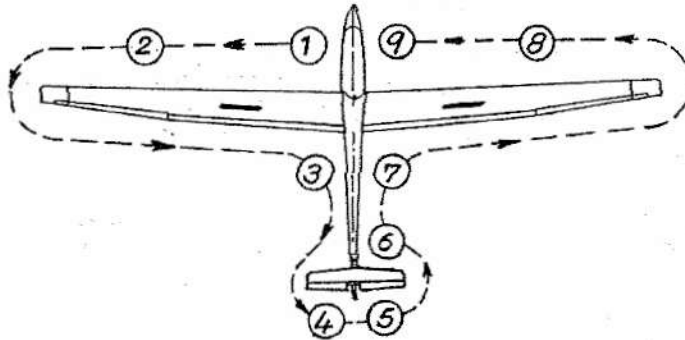

When going around the sailplane, check its surfaces for cracks, dents, and unevenness. In case of doubt, ask an expert for advice.

- (1) a. Open the canopy.
- b. Check the main bolt for security.
- c. Make a visual check for all controls in the cockpit.
- d. Check the controls for full, correct, and free movements.
- e. Check for foreign particles.

June 1980

JANUS C

FLIGHT MANUAL

- (1) f. Check the tyre pressure of the main and nose wheel,
main wheel : 4.5 bar (64 psi)
nose wheel : 2.5 bar (35 psi)
- g. Check condition and function of the tow release hook.
- (2) a. Check upper and lower wing surfaces for damage.
- b. Check the attachment of the wing tip section for security.
- c. Check the aileron for proper condition and free movement.
Check for excessive play by gently shaking the trailing edge.
Check hinge bearings for damage.
- d. Check the flap for proper condition and free movement.
Check for excessive play by gently shaking the trailing edge.
Check hinge bearings for damage.
- e. Check the air brake for condition, accuracy of fit, and locking.
- (3) a. Check the fuselage for damage, especially on the lower surface.
- b. Check that the static vent holes on the fuselage tail cone (1.0 m forward of the fin) are clear.
- (4) a. Check the horizontal tailplane for correct attachment and locking.
- b. Check the elevator and rudder for free movement.
- c. Check the trailing edges of rudder and elevator for damage.

June 1980

JANUS C

FLIGHT MANUAL

- (4) d. Check for excessive play by gently shaking the elevator and rudder.
- (5) Check condition of tailskid (or tail wheel - if installed, tire pressure 2.5 bar/36 psi).
- (6) If a T.E. venturi is used, install it and check the lines (when blowing gently into the venturi, the connected variometers show climb).
- (7) See (3).
- (8) See (2).
- (9) Check the static pressure vents (6 cm forward of the front instrument panel) and the pitot tube in the fuselage nose to ensure that they are clear. Blowing gently into the pitot tube should produce an A.S.I. reading.
- (10) Water can be drained from the lines for the pitot, static, and T.E. system by taking off the tube connectors behind the instrument panels.

After heavy landings or excessive flight loads, the frequency of the flexural wing vibration should be checked (approx. 145 / min.).

The whole sailplane has to be checked for surface cracks and other damage. For this purpose the sailplane should be disassembled.

If damages are observed (e.g. surface cracks in the fuselage tail cone and on the tailplane, delaminations on the wing spar stubs and at the bearings in the root ribs etc.) the sailplane must be grounded until the damage has been repaired by a qualified person.

4.2 Cockpit description

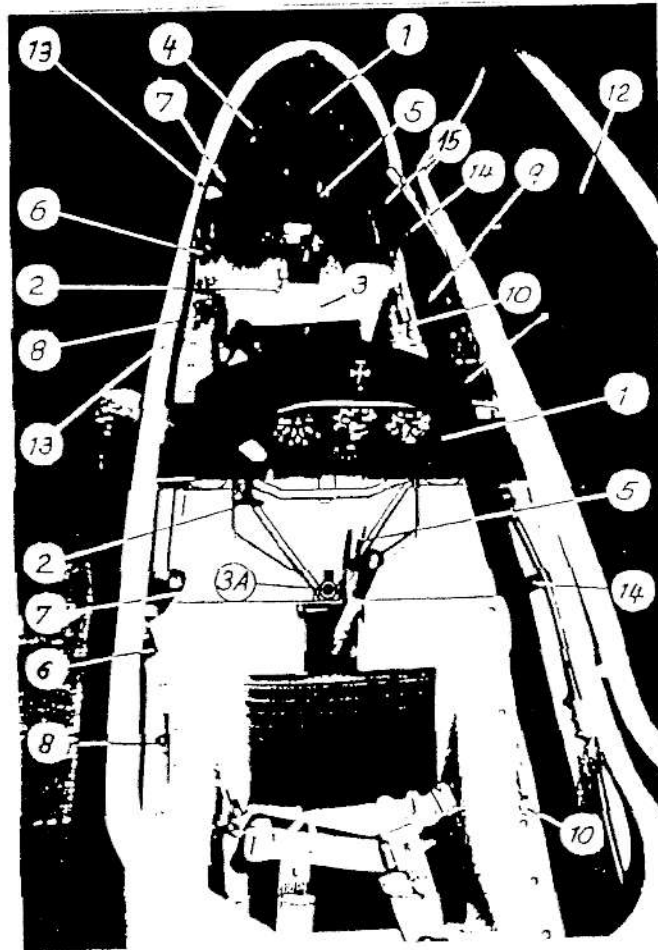

MODIF. BULLETIN NO. 295 - 21
MODIF. BULLETIN NO. 295 - 25

January 1983
November 1987

All instruments and controls are within easy reach of the pilots.

(1) Instrument panels

With canopy open the instruments are well accessible. The front instrument panel is attached to the fuselage canopy frame, the rear panel to the steel tube frame between the seats. The instrument panels and their covers are easy to remove after taking off the attachment bolts.

(2) Tow release

Front seat: Yellow T-grip on the left side base of the instrument panel console.

Back seat : Yellow T-grip on the left side of the instrument panel.

The tow rope is released by pulling the grips.

(3) Rudder pedal adjustment (front seat)

T-grip on the right side base of the instrument panel console.

Forward adjustment:

Release the lock by pulling the T-grip and push the pedals with heels into the desired position and let them engage the nearest notch.

Backward adjustment:

Pull the T-grip until the pedals have the desired position. A short push with the heels (not toes) will engage the pedals in the nearest notch with an audible click.

The adjustment of the pedals is possible on the ground and in the air.

June 1980

(3 A) Rudder pedal adjustment (rear seat)

Locking device on pedal mount on the floor of the cockpit.

Forward/backward adjustment:

Pull up locking pin by its ring, slide pedal mount into desired forward or aft position and push locking pin down into nearest recess.

Pedals may be adjusted on the ground or in the air.

ctd. on page 27

- (4) Ventilation: Small black knob at the left side of the front instrument panel.

Pull - Close
Push - Open

In addition the sliding windows or the air scoops in the windows may be used for ventilation.

- (5) Wheel brake: Brake operating lever fitted to both control sticks.

- (6) Airbrake lever and wheel brake control: Blue handles directed downwards on the left side cockpit wall.

Forward position - Airbrakes closed and locked

Pulled back approx.
40 mm (1.6 in.) - Unlocked

Pulled fully back - Airbrakes fully extended and wheel brake actuated

- (7) Flap control lever: Upwards directed handles on the upper left cockpit side fairing.

Forward position - High speed range

Backward position - Low speed range

- (8) Trim: Green ball shaped knobs on the left seat mould support.

The spring loaded trimmer is adjusted gradually by moving the knob slightly inwards, sliding it into the desired trim position and moving it outwards to lock.

forward position - nose heavy
rearward position - tail heavy

(9) Water ballast dumping

Black ball knob on the right front seat cockpit wall.

Backward position - Dump valve closed

Forward position - Dump valve open

Move the knob in the forward position downwards to lock.

(10) Not applicable

(11) Parachute rib cord

Attachment provisions:

Front seat - Steel tube frame between the seats, red mark.

Back seat - Red ring on the front left side of the main fuselage steel tube frame.

JANUS C

FLIGHT MANUAL

(12) Canopy

The one-piece plexiglass canopy hinges on flush fittings.

Take care that the cable which holds the canopy in place is attached.

(13) Canopy lock

Red ball knob on the left canopy frame.

Forward position - locked

To open the canopy, pull the knob backward and raise canopy.

(14) Emergency canopy jettison

Red ball knob on the right side of the cockpit side fairing.

Forward position - locked

To jettison the canopy, first open it, then pull the jettison knob backward and push the canopy clear.

(15) Retractable main wheel

Black handle on right seat mould support.

Retract: Disengage handle, pull back and engage in rear recess.

Extend : Disengage handle, push forward and engage in front recess.

JANUS C

FLIGHT MANUAL

Cockpit data- and reference placards

Identification plate (fireproof)

<input type="text"/>	
Manufacturer:	
SCHEMPP-HIRTH Kirchheim/Teck	
Type:	<input type="text"/>
Serial No/Yr of Mfr:	<input type="text"/>
Type Certificate No.	<input type="text"/>

Operating limits

<u>Max. All-up weight: 700 kg (1543 lb)</u>		
<u>Maximum Speeds (I.A.S.)</u>	<u>knots km/h</u>	
Flap settings +8,0,-4,-7	135	250
Flap setting L	76	140
Rough air	97	180
Maneuvering speed	97	180
Aerotow	97	180
Auto/winch launch	81	150
U/C extension	97	180

Weak links for towing:
Max. 825 daN (1819 lb)
Main wheel tire pressure:
4.5 bar (64 psi)

Modif. Bulletin No. 295 - 21
Technical Note No. 295 - 20

January 1983
April 1990

Loading plan

Cockpit load kg		two seat		single-seat	
		min.	max.	min.	max.
front seat	kg lbs	70 * 154	110* 242	70* 154	110* 242
back seat	kg lbs	no limit	110* 242	--	---

*) As the actual minimum or maximum seat loads of this sailplane (to which this manual refers) may differ from the above typical weights, the seat load placard in the cockpit must always show the actual weights from the log chart on page 14.

Check List before take-off

- o Parachute put on properly ?
- o Strapped in safely ?
- o Back rest and rudder pedals in comfortable position?
- o Operating handles and instruments well accessible ?
- o Air brakes locked after having checked the function ?
- o Movement of control surfaces checked ?
- o Flight controls unrestricted ?
- o Trim adjust properly ?
- o Wing flaps in take-off position ?
- o Canopy closed and locked ?

Only without waterballast

**the following acrobatic
maneuvers are permitted:**

- (a) Inside Loops
- (b) Turns
- (c) Spins
- (d) Lazy Eight

Operating handles and knobs

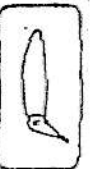
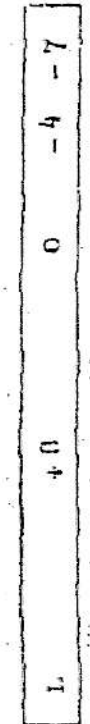

WING FLAPS :|

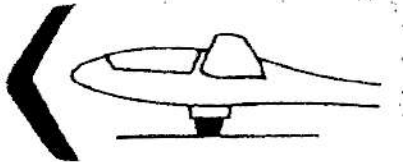

U/C extended

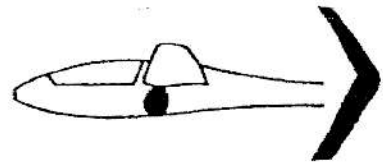

U/C retracted

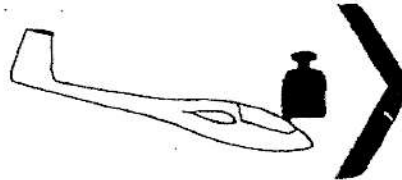
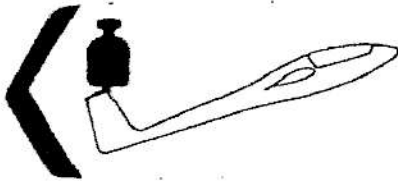

Trim

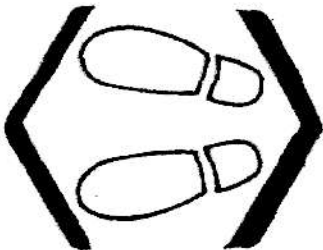

Pedal adjustment

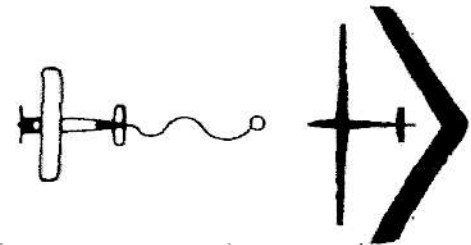

Tow release

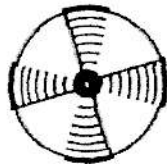

Ventilation



Airbrakes

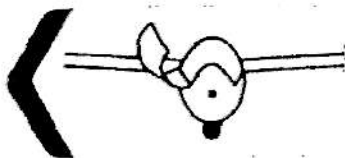

Canopy opening



Wheel brake

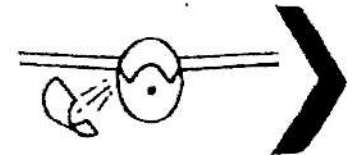

Canopy jettisoning

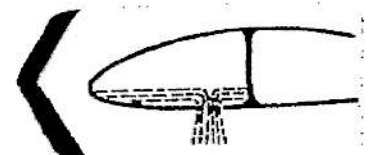

Water ballast
Jettisoning

4.3 Pre-take-off checks

See cockpit placards

4.4 Take-off

Aerotow:

~~If installed, the nose hook should be used for aerotow.~~

The maximum permissible towing speed is $V_T = 180 \text{ km/h (97 kt)}$ with flaps set at " -4° ".

For aerotow, hemp and perlon ropes of 30 to 60 m (98-197 ft) were tested.

Flap setting for the take-off run: " -4° ".

For take-off with the C.G. in a forward to intermediate position, set the trim at "normal" and in the case of intermediate to rearward C.G. positions at "nose heavy".

As the tow rope tightens apply the wheel brake gently to avoid an overrunning of the rope.

With the C.G. in a forward position, the nose wheel contacts ground, so it is advisable to start the ground run with the stick fully pulled back until the nose wheel lifts, then ease the stick forward and let the sailplane run on its main wheel.

With the C.G. in normal positions, the elevator should be neutral for the ground run; in the case of rear C.G. positions it is recommended that down elevator is applied until the tail lifts.

At higher speeds during the take-off run, the flaps should be reset at " $+8^\circ$ ".

After lift-off, between about 70 to 90 km/h (38 to 49 kt), depending on all-up mass and flap setting, the trim can be reset for minimum control stick loads.

The undercarriage may be retracted during the aerotow; this is not, however, recommended at low altitude, as changing hands on the stick could easily cause the aircraft to lose station behind the tug.

TECHNICAL NOTE NO. 295 - 9

MODIF. BULLETIN NO. 295 - 21

MODIF. BULLETIN NO. 295 - 27

July 1980

January 1983

August 1989

The normal towing speed is 100 to 120 km/h (54 to 65 knots) with flap setting +8°. At speeds of 130 km/h (70 knots) and higher flap setting 0° is recommended. With water ballast, the normal towing speed should be increased about approx. 20 %.

When releasing the rope, pull the yellow grip fully several times and turn off but after positive release.

Winch launching

Maximum permissible launching speed :

$$V_W = 150 \text{ km/h (81 knots).}$$

Before take off, set the trim on normal with the C.G. in forward to intermediate and fully forward with the C.G. in intermediate to rearward positions.

The normal take-off flap setting is +8°.

When starting the ground run, apply wheel brake gently to avoid an over-run of the winch cable.

The sailplane shows a normal behaviour during the ground run and the lift-off. There is no tendency to veer off or to climb excessively steep.

If the sailplane with a high cockpit load is standing on the nose and main wheel, the ground run should be started with stick fully pulled back until the nose wheel has ground clearance, then ease the stick forward.

With the C.G. in normal positions, the ground run is made with elevator in neutral position.

For light pilots it is recommended to make the first launches with stick fully pushed forward.

With normal cockpit load and without water ballast, the towing speed should not be less than 90 km/h (49 knots), and with

June 1980

water ballast not less than 100 km/h
(54 knots).

The normal launching speed is 100 km/h
(54 knots) and with water ballast 115 km/h
(62 knots).

At the top of the launch, the cable normally
is released automatically, nevertheless pull
the release grip several times to ensure
that the cable has released.

4.5 Free Flight

This sailplane has pleasant flight
characteristics and can be flown without
effort at all speeds, weights, and C.G.
positions (with and without water ballast).

The spring type trimmer is gradually
adjusted. With the C.G. in normal position,
the sailplane can be trimmed from 75 km/h
to 180 km/h (40 to 97 knots)

It is possible to roll the sailplane from
a steady 45° banked turn through an angle
of 90° without difficulty and without any
noticeable skidding.

Full aileron and rudder can be applied.
Time taken to reverse the direction of
the turn :

Flap setting	+ 8°
Airspeed	110 km/h (59 knots)
Time	3.5 sec.

Performance (at W/S = 31.5 kg/m²)

Stalling speed 65 km/h (35 knots)
(flap setting +8°)

Min. sinking at 85 km/h 0.6 m/sec.
(flap setting +8°) (46 kts) (1.97 ft/s)

Best L/D at 100 km/h 43
(flap setting 0°) (54 kts)

June 1980

Wing Flaps

The wing flaps have the purpose to adapt the laminar bucket of the wing airfoil to the respective airspeeds in the best way.

Since the laminar buckets of the applied airfoil for the different flap settings are covering each other widely, three flap settings for the normal flight and one setting for the high speed flight should be sufficient.

Application	Flap setting	Airspeed W/S = 31.5 kg/m ²	
		km/h	knots
Thermic flight	+ 8°	90-120	49-65
Best glide	0°	90-120	49-65
Flight between thermals	- 4°	110-160	59-86
High speed flight	- 7°	150-250	81-135

With water ballast the speeds increase up to approx. 20 %.

The above quoted speeds in thermic flight relate to the straight flight condition.

In turning flight the speeds increase dependent on the angle of bank.

June 1980

4.6 Low speed flight and stall

To become familiar with the sailplane it is recommended to test the stalling characteristics at a safe height. Stalls should be approached from straight flight and from turning flight with approx. 45° of bank, using the various flap settings.

Stall from straight flight

Following stalling speeds in straight flight have been determined :

All-up weight	457 kg		700 kg	
C.G. position	270 mm		77 mm	
Stalling speed				
airbrakes retracted				
flap setting +8°	62	33	73	39
flap setting 0°	67	36	80	43
flap setting -7°	70	38	84	45
airbrakes extended				
flap setting +8°	65	35	81	44

With airbrakes retracted a stall warning occurs between 62 and 86 km/h (33 and 46 knots), dependent on wing loading and flap setting. It begins with a slight buffeting and vibration of the horizontal tailplane, the aileron becomes spongy.

With airbrakes extended the sailplane vibrates already 5 km/h (3 knots) above stalling speed.

June 1980

When pulling the control stick slowly further back, the speed increases again until the sailplane with the C.G. in rear positions usually drops the wing.

With the C.G. in forward positions and control stick fully pulled back, the sailplane stalls without wing or nose dropping. The control stick then should be eased forward immediately.

With airbrakes extended, the loss of height during recovery from the stall is approx. 50 to 60 m (164 to 197 feet).

Stall from turning flight

At the stall from turning flight with 45° of bank, slight tumbling motions occur, which however can be easily controlled. The sailplane rolls slightly inwards and drops the nose when easing the elevator control forward. Normal level flight is regained by normal use of the flight controls. There is no uncontrollable tendency for the sailplane to spin. With the C.G. in forward positions the sailplane usually stalls without wing or nose dropping.

The variation of the speed at the stall from turning flight resembles that at the stall from straight flight.

The sailplane with the C.G. in rear positions enters a spin by applying full rudder at the stall. Safe recovery from the spin is effected by the standard method, which is defined as:

- a) apply opposite rudder (i.e. against direction of rotation of the spin;
- b) pause;
- c) ease the control stick forward until rotation ceases and a laminar flow is restored;

June 1980

- d) neutralize the rudder and allow the sailplane to dive out gently.

4.7 High speed flight

During high speed flight particular attention should be paid to the maximum speed limits associated with the various flap settings. These speed limits are colour coded on the A.S.I.

Full control movements must only be used up to $V_A = 180$ km/h (97 knots).

At $V_{NE} = 250$ km/h (135 knots) only 1/3 of the full control movements is permissible. Be cautious to avoid sharp elevator deflections.

In strong turbulence (e.g. in wave rotors, thunder clouds, visible whirlwinds or crossing over mountain ridges) the speed in rough air $V_{RA} = 180$ km/h (97 knots) must not be exceeded.

With the C.G. in rear positions the required control stick movement from the stalling speed up to the maximum speed is relatively small, the change of speed however is observed by a clear change of the stick force.

The airbrakes can be extended up to $V_{NE} = 250$ km/h (135 knots), however they should only be used in emergency or if the max. permissible airspeeds (see page 5) are inadvertently exceeded.

Attention also is to be paid to dive out more gently with airbrakes extended than with airbrakes retracted.

The terminal velocity in the dive at maximum all-up weight with airbrakes extended and flap setting $+8^\circ$ is 250 km/h (135 knots), where the angle of the flight path is set to 45° .

4.8 Flight with water ballast

The water tanks are integral compartments in the nose of the wing.

Filling

The tanks are filled through a hole in the upper surface of the wing nose. The filling holes are closed by plug caps. With the aid of a pin which is inserted into the 5 mm hole, the caps can be pulled out. The 5 mm hole serves also as a vent and must therefore kept clear. In addition the tanks are vented by plastic tubing, leading from the top point of the tanks through the wing with outlet at the end of the ailerons.

The wing tanks have a capacity of 120 kg water each. Corresponding to the cockpit load (pilot and parachute) the tanks are to be filled insofar that the maximum all-up weight of 700 kg (1543 lbs) is not exceeded (see loading plan, page 10).

Both tanks should always be filled with the same quantity of water, so that the lateral stability is not detrimentally affected.

When flying with partly filled tanks, no noticeable water movement occurs, due to the baffle ribs.

Dumping

The dumping of the water tanks is done via an opening on the lower wing surface near the root rib.

The connection of the water dumping mechanism of the wing to the fuselage is made automatically when assembling the wings.

June 1980

The dump valve operating handle (ball knob) is installed at the right cockpit wall of the front seat.

To open the dump valves, push the knob forward and lock by moving it downwards.

If the improbable case should happen, that the tanks are dumped unequally or one-sided, the speed should be increased corresponding to the higher all-up weight. Stalls should be avoided. At landing attention should be paid to the tendency for the sailplane to veer off, due to the earlier ground contact of the heavier wing.

Note:

1. During longer flights at temperatures below 0°C (32°F) the water ballast must be drained off in any case to avoid icing.
2. If an average rate of climb of not more than 1.5 m/sec. (2 knots) is expected, the use of water ballast is not recommended. The same applies to flights in narrow thermals where steeply banked circling is required.
3. Before off-field landing the water tanks should be drained off.
4. Never park the sailplane with filled water tanks because of icing risk. Before parking, drain off all water, remove the filling caps and let the tanks dry.
5. If the dump valves drip when the tanks are filled, the valve seats should be greased before the next filling. This is done by pulling down the valve cap using the mounting bolt of the tailplane.

June 1980

4.9 Cloud flying

The sailplane has sufficient strength and stability for cloud flying. It is easy to control and has a stable circling behaviour.

Nevertheless observe certain basic rules.

Do avoid extreme airspeeds in any case. Spins must not be applied as a rescue action, because the sailplane may enter a spiral dive. It is recommended to extend fully the airbrakes already at a speed of 150 km/h (81 knots), respectively at a load factor above 2 g.

The equipment necessary for cloud flying is listed in section 2.9, page 16.

4.10 Flying at temperatures below freezing point

When flying at temperatures below 0°C (32°F), as in waves or during the winter season, it is possible that the controls cannot be operated with sufficient ease and smoothness. Ensure that all control elements are free from moisture to avoid freezing up.

This in particular applies to the airbrakes.

From experience, it is of advantage to coat the top covers of the airbrakes with vaseline to avoid jamming by freezing up.

Move the controls frequently.

When flying with water ballast, observe the instructions in section 4.8, page 41.

Janus C

FLIGHT MANUAL

Warning:

The polyester coating on this sailplane is known from many years experience to become very brittle at low temperatures.

Particularly when flying in wave at altitudes above about 6000 m (approx. 20000 ft), where temperatures of below -30°C (-22°F) may occur, the gel coat, depending on its thickness and the stressing of the aircraft's components, is prone to cracking.

Initially, cracks will only appear in the polyester coating, however, with time and changing environment, cracks can reach the epoxy/glass matrix. Cracking is obviously enhanced by steep descents from high altitudes at associated very low temperatures.

Therefore, for the preservation of a proper surface finish free from cracking, the manufacturer strongly advises against high altitude flights with associated temperatures of clearly below -20°C (-4°F).

A steep descent with the airbrakes extended should only be conducted in case of emergency.

4.11 Restricted Aerobatics

(only permissible without water ballast)

The Janus C is permitted to carry out the following aerobatic manoeuvres :

- | | |
|----------------|-----------------|
| a) Inside loop | b) Stalled turn |
| c) Spins | d) Lazy Eight |

In the following the parenthesized speeds refer to higher wing loading (two-seat).

Inside loop

Enter the manoeuvre at an indicated speed of 180 (200) km/h or 97 (108) knots at a flap setting -7° . In the medium part of the manoeuvre the flaps should be re-set on 0° . Speed during recovery from the manoeuvre: 160 (175) km/h or 86 (94) knots.

Stalled turn

Enter the manoeuvre at an indicated speed of 180 (200) km/h or 97 (108) knots with flap setting -7° . Apply full rudder in the vertical climb at a speed of approx. 140 km/h or 76 knots. Pull-out speed is 160 (180) km/h or 86 (97) knots.

Spins

Spins are only possible with the C.G. in rear positions. Select flap setting $+8^{\circ}$. Enter the spin from a stall by applying full rudder. Pull the control stick fully back during spinning. Recover from the spin by easing the control stick forward with aileron in neutral position and by applying opposite rudder. Pull-out speed is 140 to 160 km/h or 76 to 86 knots. With the C.G. at the aftmost limit the spin is continued for approx. one turn after action for recovery has been initiated.

June 1980

Lazy Eight

Enter the manoeuvre at an indicated airspeed of 180 (200) km/h or 97 (108) knots and with flap setting -7°.

After pulling up in a 30° to 45° climb enter a turn at approx. 120 km/h or 65 knots. Pull-out speed: 160 (180) km/h or 86 (97) knots.

4.12 Approach and landing

Approach and landing are conducted without difficulty with flap setting L and at a speed of approx. 90 to 105 km/h (48 to 57 knots), dependent on the wing loading, also with lateral wind components of up to 20 km/h (10 knots).

The airbrakes open smoothly. They are very effective, therefore a slight forward elevator control is necessary to compensate the reduction of speed due to the braking effect.

The gliding angle with airbrakes fully extended is approx. 1 to 6.5.

The sideslip is well controllable and can be used as a landing aid, also with airbrakes extended. The sideslip should be initiated and recovered with airbrakes retracted to avoid the influence of the airbrake turbulence on the horizontal tailplane.

Touch down is on the main wheel and tail skid (or wheel) simultaneously.

The effectiveness of the wheel brake is good - it is actuated by extending the airbrakes fully (pulling the stick-mounted brake lever is less effective).

To avoid a long landing run, care is to be taken to touch down at a minimum speed of 70 to 90 km/h (38 to 48 knots), dependent on the wing loading.

A touch-down at a speed of 95 km/h (51 knots) instead of 70 km/h (38 knots) means doubling the brake energy and therefore a considerably longer landing run.

During the landing run, the flaps should be moved forward to setting 0° or -4° to improve the effectiveness of the aileron control.

When landing with water ballast in one wing only, attention is to be paid to the tendency for the sailplane to veer off, due to the earlier ground contact of the heavier wing.

When flying in rain or with iced-up wing surface, the performance and the aerodynamic qualities are deteriorated.

Therefore be cautious when landing!

Increase the approach speed at least 10 km/h (6 knots) to 100 to 115 km/h (54 to 62 knots).